

5800 Uplander Way  
Culver City, CA 90230  
Tel (310) 642-7975  
sales@apichip.com

# 10 GHz Photodiode – 80mA photocurrent

Part # ARx10-80-N-DC-FL-FC

## PRODUCT FEATURES

- Ultra High responsivity
- Very high optical power handling
- High linearity
- Very low phase noise
- Extended temperature range
- Laser welded assembly
- Hermetically sealed
- XLMD MSA footprint compliant package

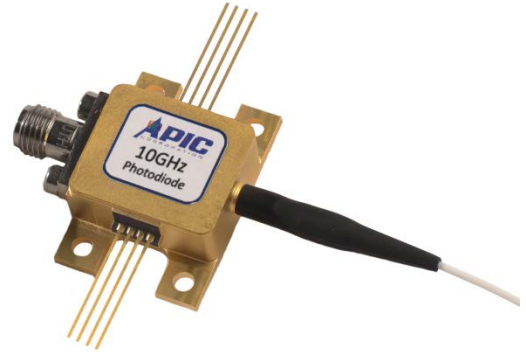

## APPLICATIONS

- RF over fiber interconnects requiring high gain, high dynamic range and low noise figure
- Harsh environments

## DESCRIPTION

Packaged proprietary design InGaAs photodiode (PD), that is optimized for high input optical power and maximum output current linearity. The device is designed to work for RF over fiber links that require high dynamic range, low noise figure and high RF gain. The internal components are soldered and laser welded, ensuring maximum reliability and performance stability with ambient temperature variation. To ensure maximum RF gain the receiver is packaged with no internal 50 Ohm termination and DC coupled output. The device operates with external bias T connected to the RF output port.

## ORDERING INFORMATION

ARx10-80-N-DC-FL-FC

*FL* = Fiber length (in meters)  
*FC* = Fiber connector type FC/PC; FC/APC

### ABSOLUTE MAXIMUM RATINGS

Parameter	Symbol	Minimum	Maximum	Units	Condition/Comments
Photodiode Voltage	$V_{pd}$	0.1	-8	V	No illumination
Maximum optical input power	$P_{max}$		100	mW	At -3V bias
Output Power Damage Threshold	$P_{out} = I_{ph} \times V_{bias}$		300 290	mW	At -3V Bias At -5V Bias
ESD output pin	$V_{ESD}$	-250	250	V	
Fiber bend radius		10		mm	

### ELECTRO-OPTICAL SPECIFICATIONS

Parameter	Symbol	Min.	Typ.	Max.	Units	Condition/Comments
Wavelength range	$\lambda$	1500		1580	nm	
Responsivity	R	0.9	0.95		A/W	
Polarization Dependent Sensitivity (PDS)	PDL		0.1	0.2	dB	Variation in detected signal over all polarization states
RF bandwidth	$F_{3dB}$	10	11		GHz	3 dB point measured
Dark current	$I_{dark}$		50	100	nA	At 25 degrees C ambient -3V bias
PD reverse bias	$V_{PD}$	-2	-3	-5	V	Do not exceed -3V bias above 70mA photocurrent use
Optical saturation power	$P_{sat}$	19			dBm	1 dB compression point when biased at 3V
Optical Return Loss	ORL	-27	-30		dB	
Output Reflection Coefficient	$S_{22}$		NA		dB	Depends on external bias T
RF Output Termination	$R_{term}$		NA		$\Omega$	The device is not internally terminated. The external bias T sets the RF termination impedance.

**MECHANICAL SPECIFICATIONS**

Parameter	Symbol	Minimum	Maximum	Units	Condition/Comments
Height	H		8.6	mm	
Area	A		12 x 15	mm <sup>2</sup>	Mounting ears excluded
High Speed Electrical Connector					GPPO (Compatible with mini SMP)
Packaging					Hermetically sealed
Package Heat Flow					Heat sink on bottom surface
Fiber Pigtail Length		0.5	2	m	Custom lengths available
Pigtail Termination					FC/PC;FC/APC SMF28

**ENVIRONMENTAL SPECIFICATIONS (preliminary, qualification in progress)**

Parameter	Minimum	Maximum	Units	Condition/Comments
Operating Temperature	-40	+85	°C	Case temperature
Storage Temperature	-55	+95	°C	
Operating Humidity	0	90	% RH	
Shock	20 g amplitude and 11 ms duration, three shocks each axis, each direction			MIL-STD-810 Method 516, Procedure I. Non-operational.
Operational Vibration	3.56 Grms one hour each axis			MIL-STD-810 Method 514, Procedure IV.
Endurance Vibration	8.25 Grms one hour each axis			MIL-STD-810 Method 514, Procedure IV.
Reliability Performance	40,000		hours	

### RECOMMENDED ELECTRICAL CONNECTION

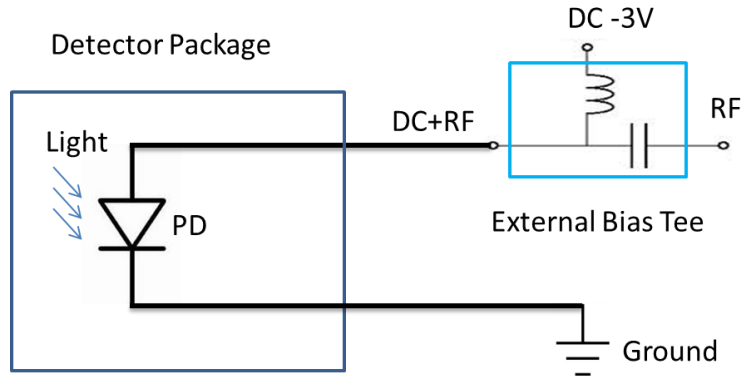

### MECHANICAL DRAWING

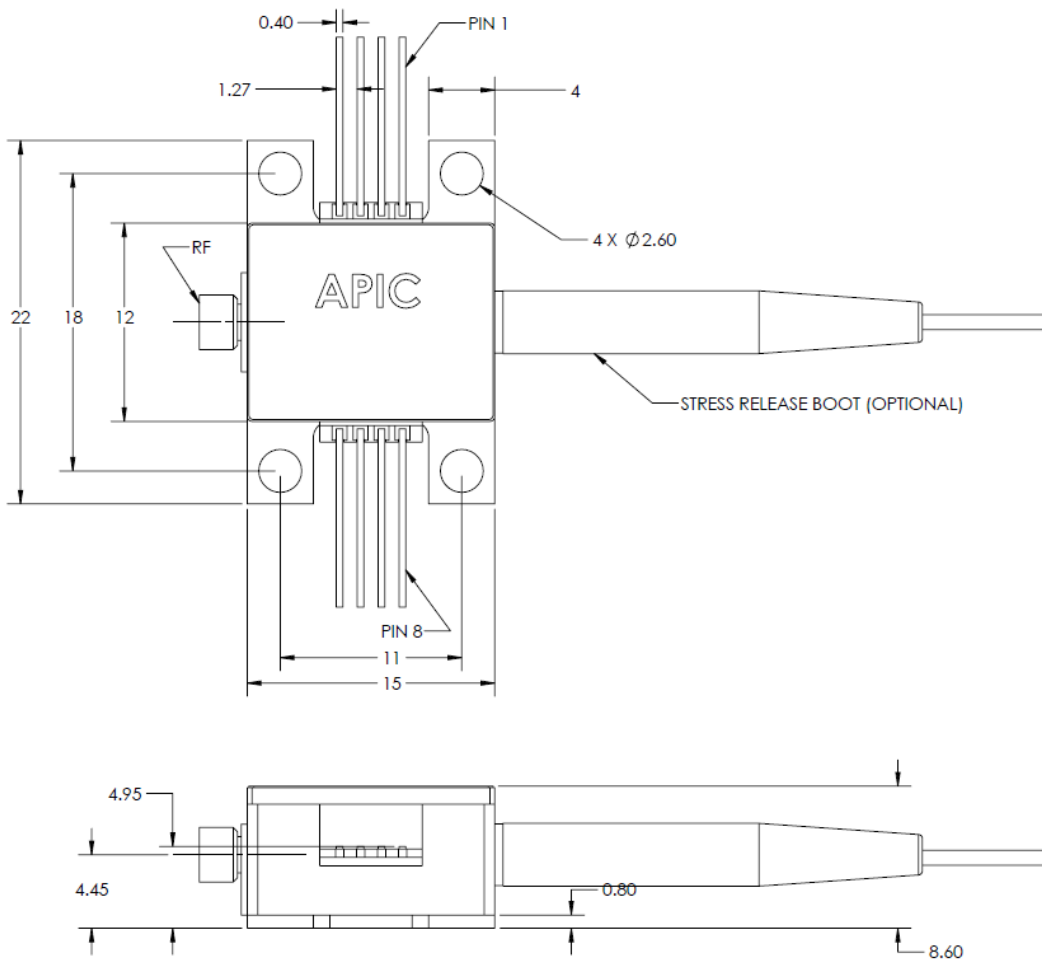

ALL DIMENSIONS IN MM

**PIN DESCRIPTION**

<b>Pin #</b>	<b>Symbol</b>	<b>Description</b>
1,3,4,5,6,8		Not connected
2 and 7	Gnd	Case Ground
RF	RF	RF signal output