



Product Specification

5800 Uplander Way
Culver City, CA 90230
Tel: (310) 642-7975
sales@apichip.com
www.apichip.com

40 GHz High Power, High Linearity Photodiode

Part #ARX-40-25-zz-DC-C-FL-FC

PRODUCT FEATURES

- High responsivity, high optical power handling capability, and high linearity
- 50Ω on-chip impedance matching option, eliminating need for bias T at the output
- Laser welded assembly
- Hermetically sealed
- XLMD MSA footprint compliant package with K-connector for RF (2.92 mm)

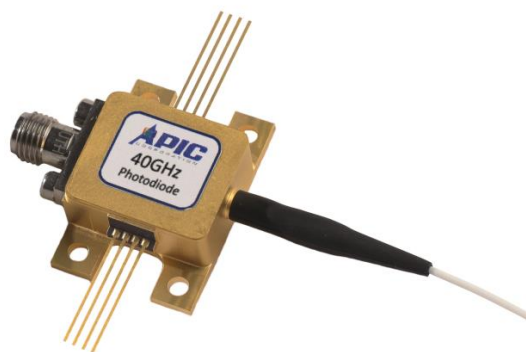

APPLICATIONS

- RF over fiber interconnects requiring high gain, high dynamic range, and low noise figure
- RFoF links in harsh environments
- Multi-level modulation communication receivers

DESCRIPTION

This product is a packaged, InGaAs photodiode (PD) using a proprietary chip design that is optimized for high input optical power, maximum output current linearity, and operation at RF frequencies up to 40 GHz. This PD is designed for RF over fiber links that require high dynamic range, low noise figure, and high RF gain at higher frequencies. The internal components are soldered and laser welded, ensuring maximum reliability and performance stability under harsh temperature and vibration environments. To ensure maximum RF output flatness, the photodiode can be delivered with a 50 Ohm on-chip termination and has a DC coupled output.

ABSOLUTE MAXIMUM RATINGS

Parameter	Symbol	Minimum	Maximum	Units	Condition/Comments
Photodiode Voltage	V_{pd}	0	-6	V	No illumination
Maximum optical input power	P_{max}		35	mW	At 5V bias
Output Power Damage Threshold	$P_{out} = I_{ph} \times V_{bias}$		100	mW	At 5V Bias
ESD output pin	V_{ESD}	-250	250	V	
Fiber bend radius		10		mm	

ELECTRO-OPTICAL SPECIFICATIONS

Parameter	Symbol	Min.	Typ.	Max.	Units	Condition/Comments
Wavelength range	λ	1,530		1,620	nm	
Responsivity	R	0.55	0.65		A/W	
Polarization Dependent Sensitivity (PDS)	PDL		0.2	0.3	dB	Variation in detected signal over all polarization states
RF Bandwidth	$F_{3\text{ dB}}$	35	40		GHz	Measured at 3 dB point
Dark Current	I_{dark}		10	200	nA	At 25°C ambient
PD Bias	V_{PD}	3	4	5	V	Do not exceed 5.5 V
Optical Saturation Power	P_{sat}	18			dBm	1 dB compression point
Optical Return Loss	ORL	-27	-30		dB	
Output Reflection Coefficient	S_{22}	-7	-10		dB	0.1 to 40 GHz
RF Output Termination	R_{term}		50		Ω	Applicable to impedance-matched version only

MECHANICAL SPECIFICATIONS

Parameter	Symbol	Minimum	Maximum	Units	Condition/Comments
Height	H		9.3	mm	
Area	A		18.6 x 15.5	mm ²	Mounting tabs excluded
RF Connector					K-connector (2.92mm)
Packaging					Hermetically sealed by laser welding
Package Heat Flow					Heat sink on bottom surface
Fiber Pigtail Length		0.95	1	m	SMF28 Fiber; Custom lengths by special order
Pigtail Termination					FC/APC

ENVIRONMENTAL SPECIFICATIONS (Preliminary, Qualification in Progress)

Parameter	Minimum	Maximum	Units	Condition/Comments
Operating Temperature	-40	+85	°C	Case temperature
Storage Temperature	-55	+95	°C	Non-operating
Operating Humidity	0	90	% RH	
Shock	50 g amplitude and 11 ms duration, three shocks each axis, each direction			MIL-STD-810G Method 516.6, Procedure I, Operational.
Operational Vibration	3.56 Grms one hour each axis			MIL-STD-810G Method 514.6, Category 12.
Endurance Vibration	8.25 Grms one hour each axis			MIL-STD-810G Method 514.6, Category 12.
Reliability Performance	40,000		hours	

ELECTROMAGNETIC SPECIFICATIONS (Preliminary, Qualification in Progress)

Parameter	Minimum	Maximum	Units	Condition/Comments
Radiated Emission	0.002	18	GHz	Meets MIL-STD-461F, RE102, Helicopters case (<70 dBμV/m)

TYPICAL MEASURED PERFORMANCE (Bandwidth versus Photocurrent S21)

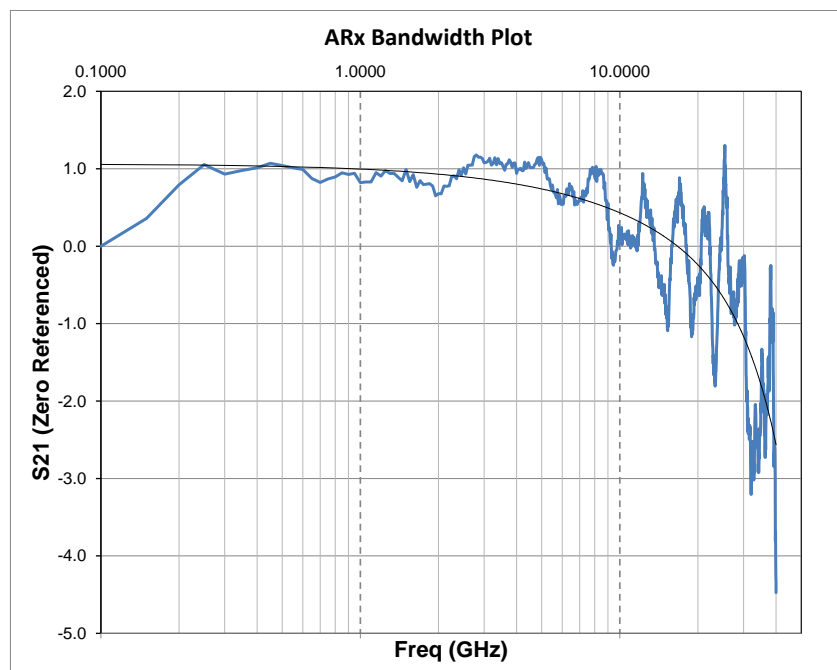

MECHANICAL DRAWING

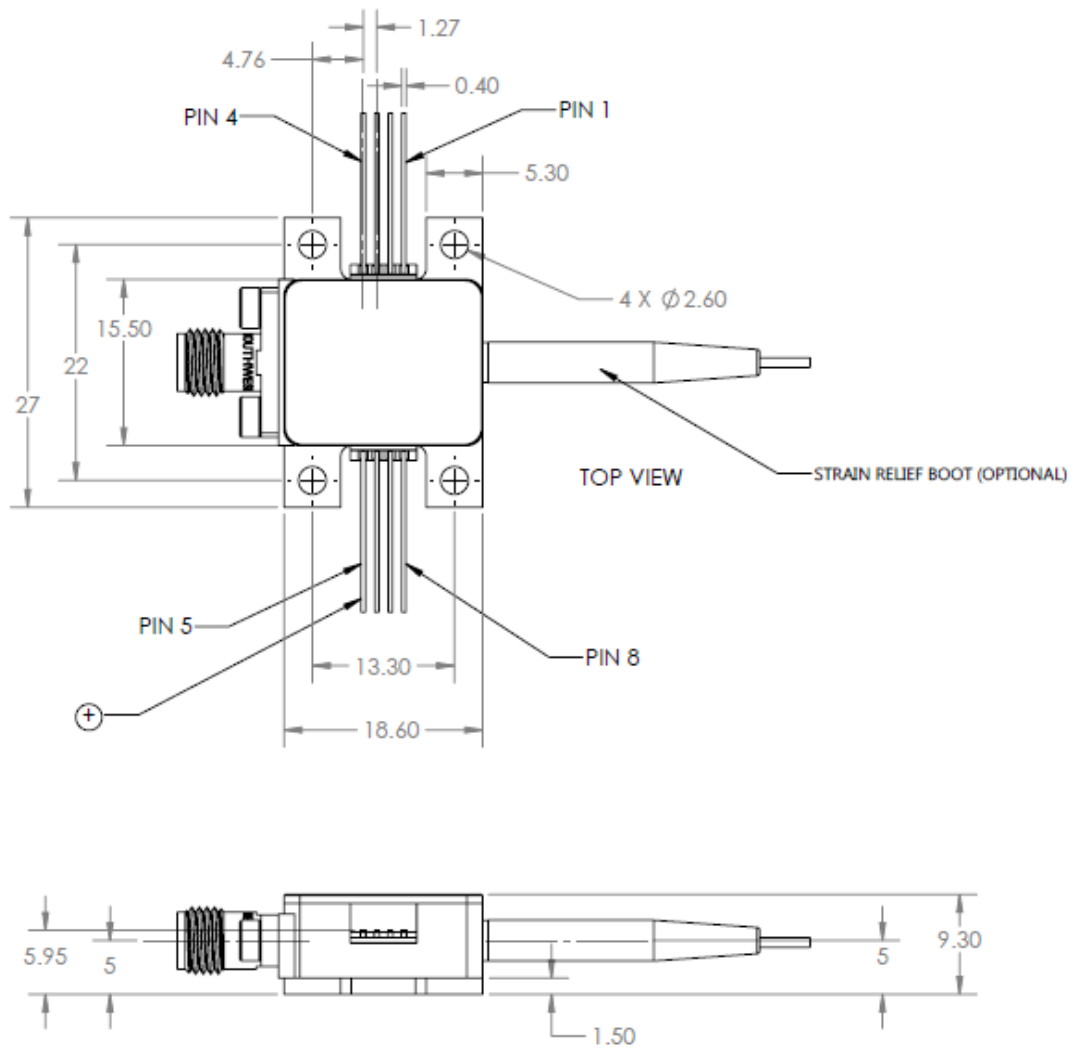

ALL DIMENSIONS IN MM

PIN CONNECTIONS

Pin #	Symbol	Description
1,3,4,6,8		Not connected
5	DC	DC bias
2 and 7	Gnd	Case Ground
RF	RF	RF signal output

ORDERING INFORMATION

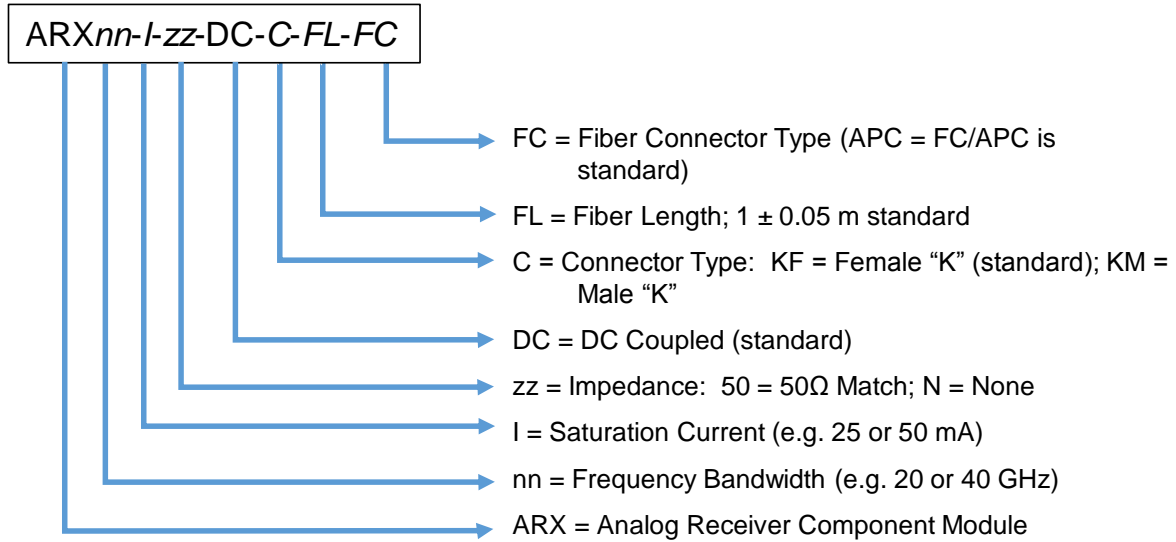

APIC Corporation
5800 Uplander Way, Culver City, CA 90230
www.apichip.com; (310) 642-7975 (ph); (310) 642-7829 (FAX)
E-Mail: sales@apichip.com