



Product Specification

5800 Uplander Way
Culver City, CA 90230
Tel: (310) 642-7975
sales@apichip.com
www.apichip.com

Low Relative Intensity Noise Analog DFB Laser Module

AL-Pxx-WLxx-165-1-FC

PRODUCT FEATURES

- High power laser source
- 14 pin, standard butterfly package and OC-48 pin compatibility
- Low RIN
- Low threshold current
- Narrow linewidth
- High sidemode suppression ratio (SMSR)

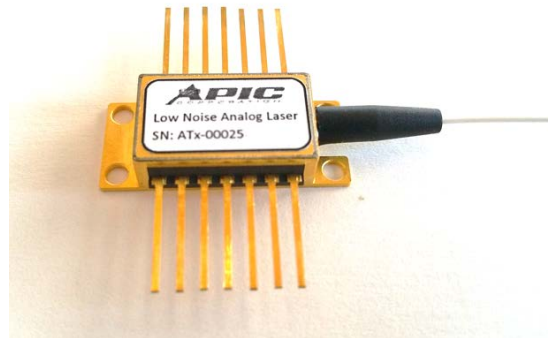

APPLICATIONS

- Broadband RF over fiber links with external/remote modulator
- Wireless networking and network backbone using DWDM
- Sensing applications requiring high power, low noise laser sources
- OEM applications in optical communications, networking, and sensors
- Cable TV networks
- Other applications requiring high power and low RIN lasers

DESCRIPTION

This ultra-low noise, high power DFB laser is based on a proprietary epitaxy and design that has been optimized to eliminate relaxation oscillations. Once biased at the nominal operating current, the laser exhibits no measurable RIN and operates in the shot noise limit. It is hermetically sealed in a standard 14 pin butterfly package with an internal thermo-electric cooler (TEC) and photodiode for power monitoring. The laser is available at customer-selected DWDM ITU wavelengths.

ABSOLUTE MAXIMUM RATINGS

Parameter	Minimum	Maximum	Units	Condition/Comments
Operating Case Temperature	-20	75	°C	With TEC, at operating current
Storage Temperature	-40	85	°C	
Laser Forward Current		600	mA	
Laser Max Forward Voltage		2.5	V	
PD Reverse Voltage		10	V	
TEC Current	-1.9	+1.9	A	
ESD	-500	500	V	

OPTICAL AND ELECTRICAL SPECIFICATIONS

Parameter	Symbol	Min.	Typ.	Max.	Units	Condition/Comments
Operational Wavelength	λ	1530		1565	nm	On standard 100 GHz ITU channel grid
Optical Output Power	P_o	40			mW	For AL-40
		60				For AL-60
		80				For AL-80
		100				For AL-100
Laser Threshold Current	I_{th}		14	25	mA	
Operating Current	I_{op}			600	mA	
Forward voltage	V_f			2.5	V	At operating bias
Linewidth	$\Delta\lambda$		250	500	KHz	At operating drive current with clean input power
Optical Return Loss	ORL	30	45		dB	
Relative Intensity Noise	RIN		-165	-160	dB/Hz	At operating current; up to 10 GHz
Sidemode Suppression Ratio	SMSR	35	45		dB	At operating current
Polarization Extinction Ratio	PER		19		dB	

MECHANICAL SPECIFICATIONS

Parameter	Symbol	Minimum	Maximum	Units	Condition/Comments
Dimensions	L x W x H	20.83 x 12.7 x 7		mm	
Fiber Pigtail Length	FL	0.95	1.05	m	Standard is 1 m; other lengths available subject to lead time and order minimums
Pigtail Termination					FC/APC, with PM single mode fiber (FC/PC not recommended)

LASER CHARACTERISTICS

The typical test data for laser module power as a function of injected current (P-I), forward voltage as a function of injected current (I-V), relative intensity noise (RIN), and laser spectrum are shown below.

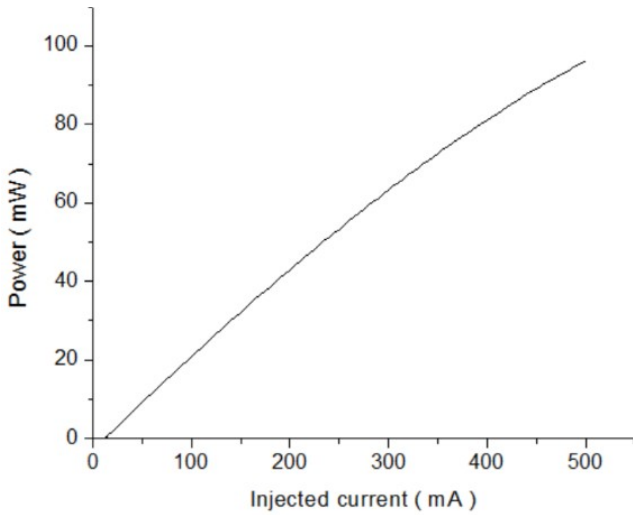

Laser P-I

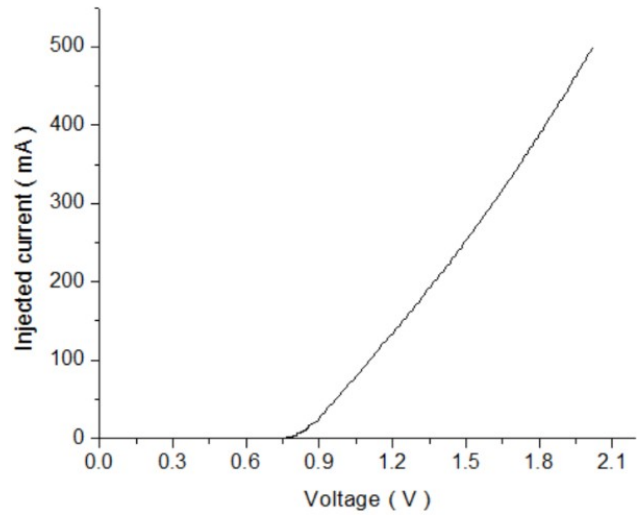

Laser I-V

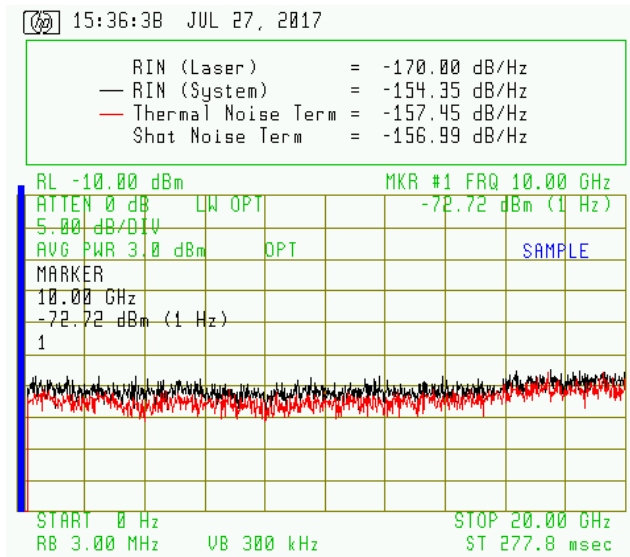

Laser RIN

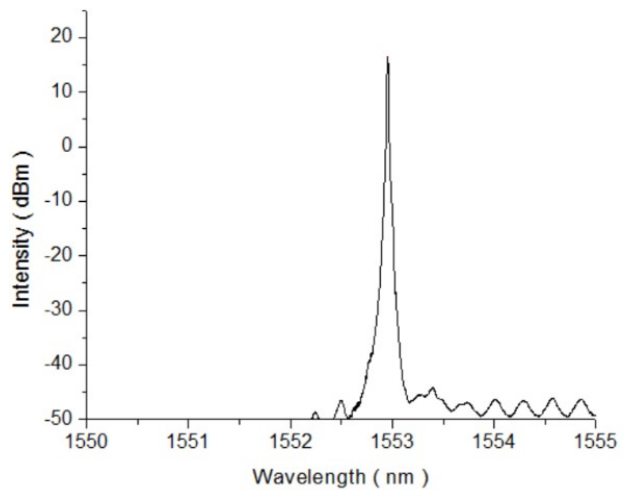

Laser Optical Spectrum

PACKAGE DRAWING

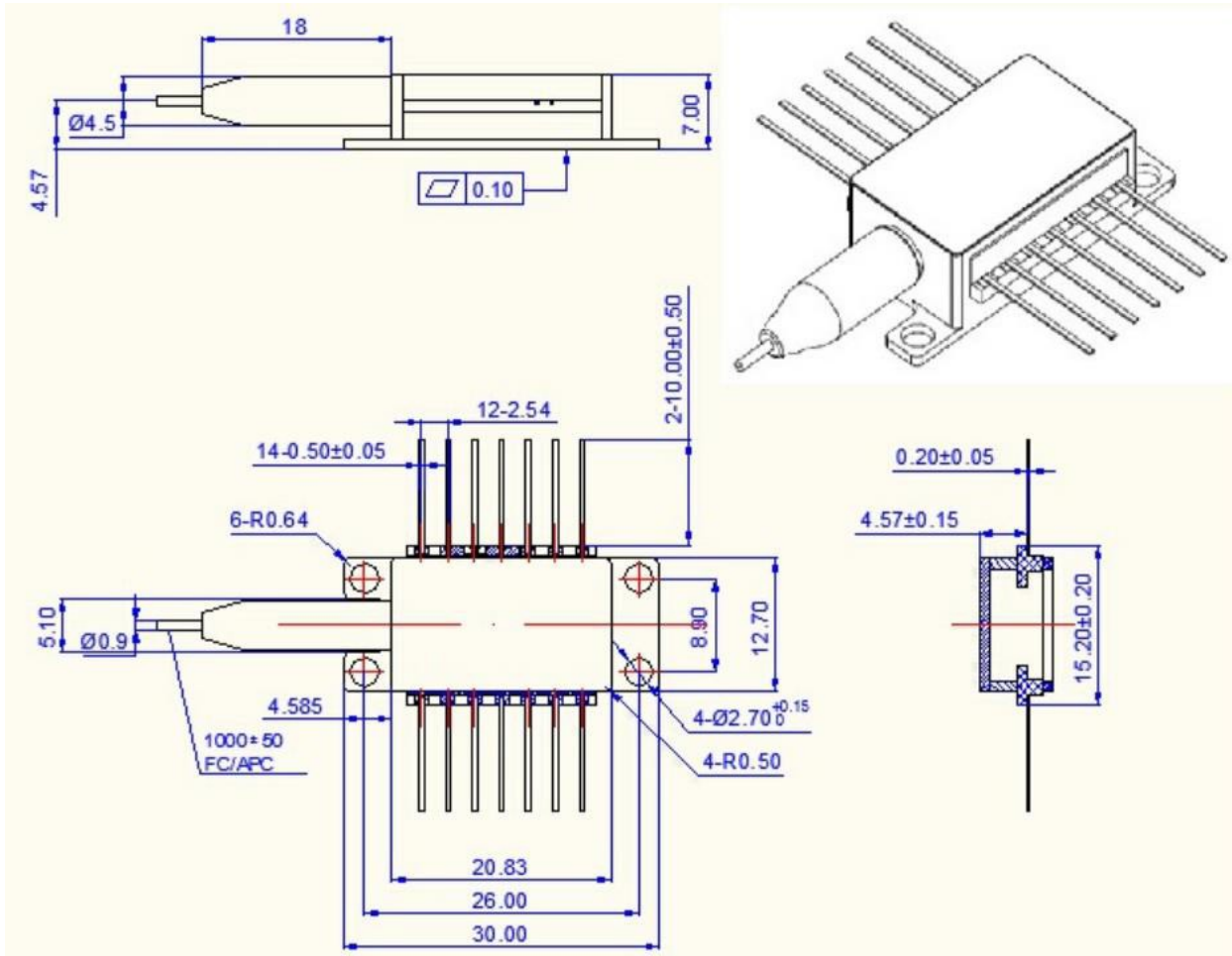

PIN ASSIGNMENTS

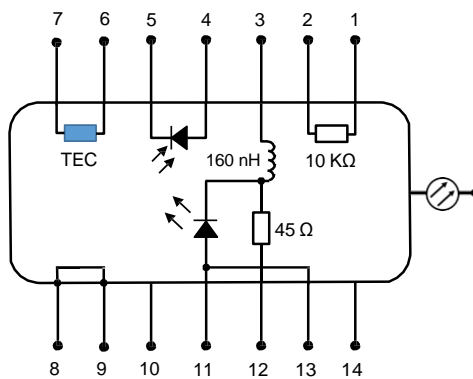

PIN Connections

Pin Number	Function
1	Thermistor
2	Thermistor
3	Laser Cathode
4	PD Anode
5	PD Cathode
6	TEC (+)
7	TEC (-)
8	NC
9	NC
10	NC
11	Laser Anode Case GND
12	RF Input (if used)
13	GND
14	NC

ORDERING INFORMATION

